

**FLowsERVE**

Pump Division

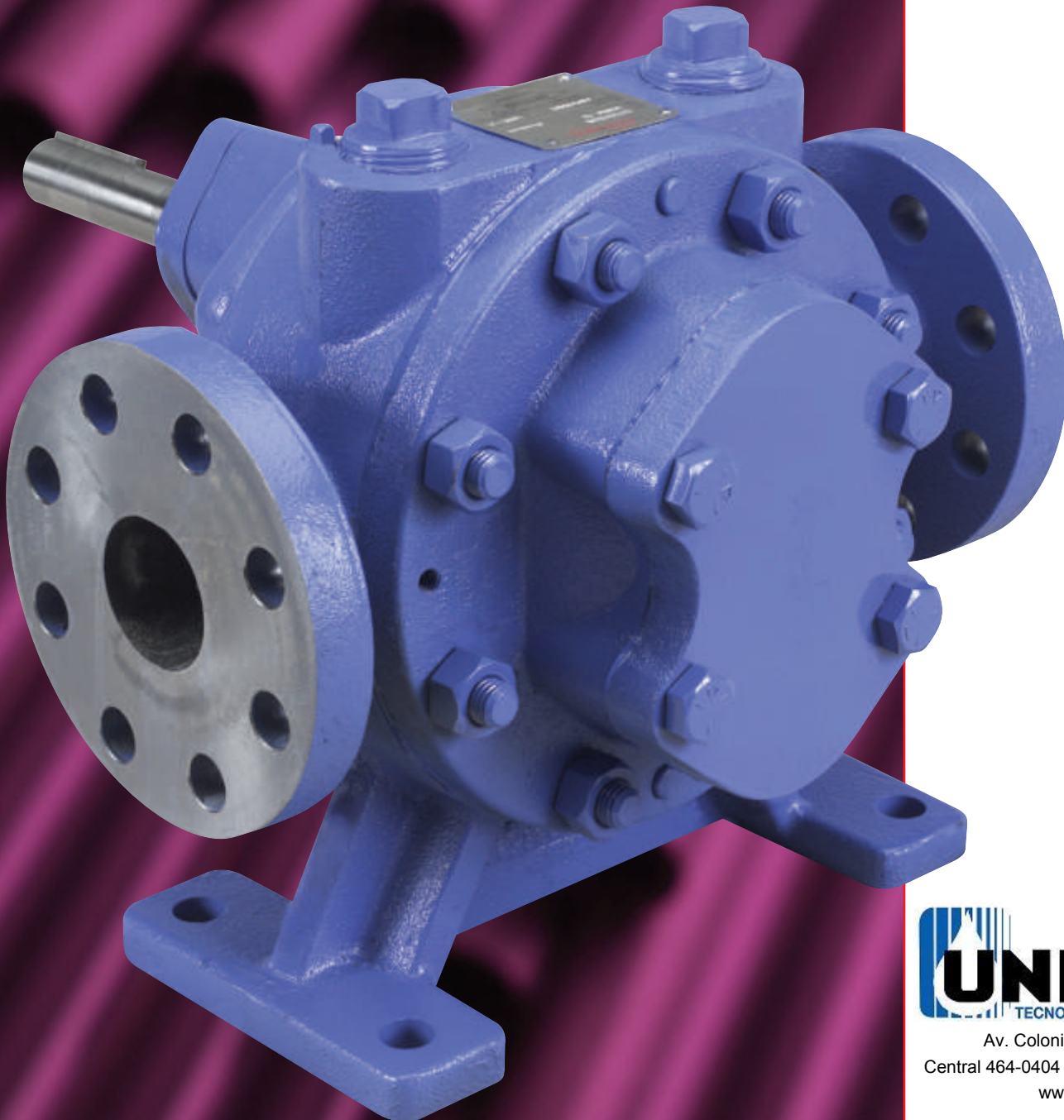

***GR Series***  
***Between Bearing,***  
***External Gear***  
***Pump***

**UNITEC**  
TECNOLOGÍAS PARA FLUIDOS®

Av. Colonial 5771 - Callao  
Central 464-0404 Email: [info@unitec.pe](mailto:info@unitec.pe)  
[www.unitec.pe](http://www.unitec.pe)

Bulletin PS-60-3a (E)

## Pump Supplier To The World

*Flowserve is the driving force in the global industrial pump marketplace. No other pump company in the world has the depth or breadth of expertise in the successful application of pre-engineered, engineered and special purpose pumps and systems.*

### Pumping Solutions

Flowserve is providing pumping solutions which permit customers to continuously improve productivity, profitability and pumping system reliability.

### Market Focused Customer Support

Product and industry specialists develop effective proposals and solutions directed toward market and customer preferences. They offer technical advice and assistance throughout each stage of the product life cycle, beginning with the inquiry.



### Dynamic Technologies

Flowserve is without peer in the development and application of pump technology, including:

- Hydraulic engineering
- Mechanical design
- Materials science
- Intelligent pumping
- Manufacturing technology

### Broad Product Lines

Flowserve offers a wide range of complementary pump types, from pre-engineered process pumps, to highly engineered and special purpose pumps and systems. Pumps are built to recognized global standards and customer specifications.

Pump designs include:

- Single stage process
- Between bearing single stage
- Between bearing multistage
- Vertical
- Submersible motor
- Rotary
- Reciprocating
- Nuclear
- Specialty

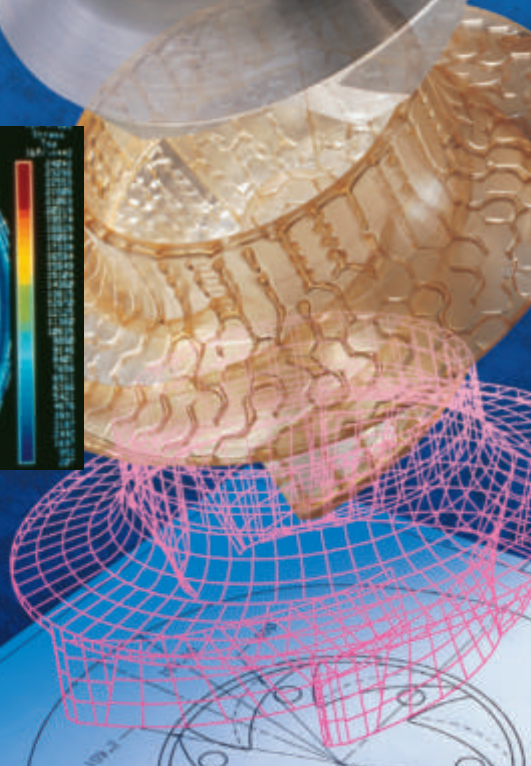
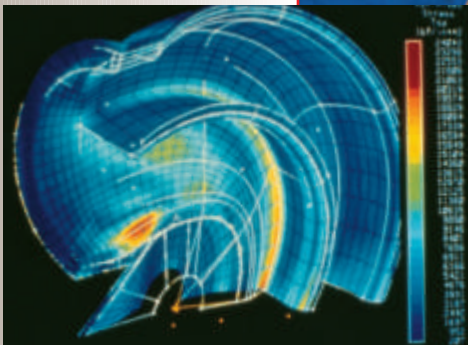
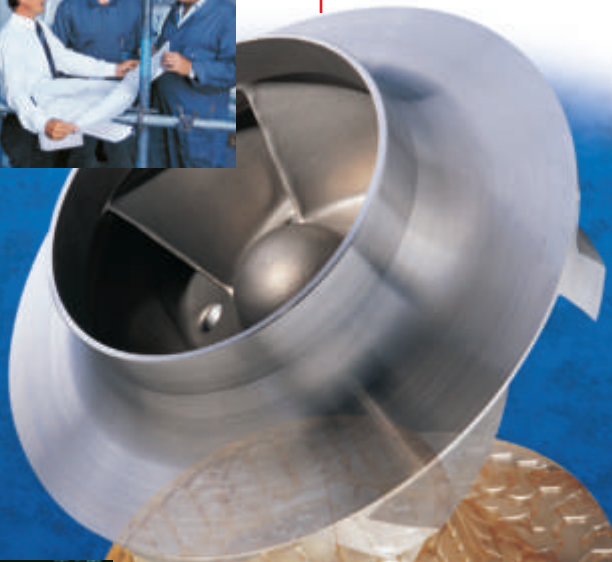

**GR Series  
Between Bearing,  
External Gear  
Pump**

**Designed for Smooth, Efficient  
Handling of Viscous Liquids**

The GR Series between bearing, herringbone gear pump has long been a work-horse within a multitude of industrial markets due to its dependability, efficiency and low life cycle cost.

**Superior External Herringbone  
Gear Design**

Designed to reliably handle viscous fluids across a broad range of flows and pressures, the GR Series' simple between bearing gear design is the most robust in the industry.

**Benefits of the GR include:**

- Pulse-free operation
- Mechanically and hydraulically balanced
- Self-priming
- No gear box required
- Speeds to 1800 rpm
- Run dry capability when packed
- Ease of maintenance
- Low NPSHR
- Only one mechanical seal
- No external lubrication required
- Improved reliability
- Minimal shaft deflection
- Long mechanical seal life
- Reduced bearing loads
- Superior high pressure capability
- Suitable for fluids with poor lubricating characteristics
- Reduced wear rates

**Typical Applications**

- Process industries
  - Paints
  - Soaps
  - Gels
  - Polymers
- OEM
  - Filtration equipment
  - Lubrication units
  - Fire foam systems
- Marine
  - Engine room fuel
  - Engine room lubrication
- Petrochemical
  - Viscous crude oil
  - Asphalt
  - Tars
  - Grease
- Power plants and utilities
  - Fuel unloading
  - Fuel oil transfer
  - Lube oil supply

**Complementary  
Pump Designs**

- GAX Series double helical gear pumps
- Gearex double helical gear pump
- Hydrex double helical gear pump
- Sier-Bath Two-Screw gear pump
- HS reciprocating gear pump

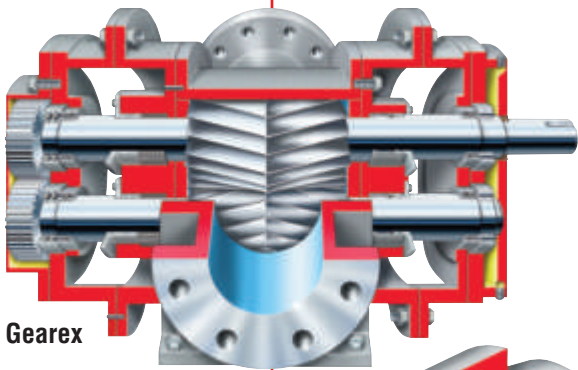

Gearex

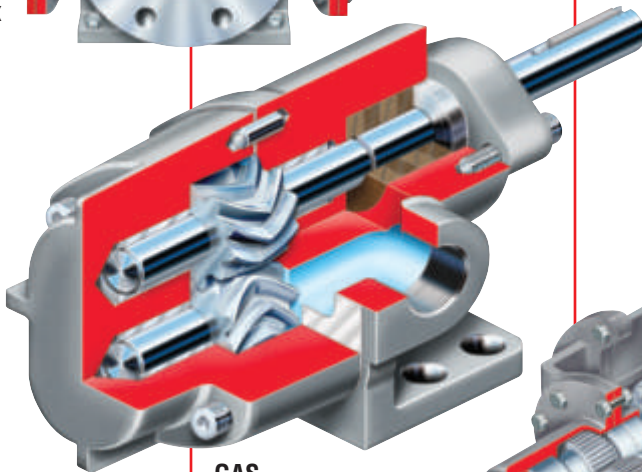

GAS

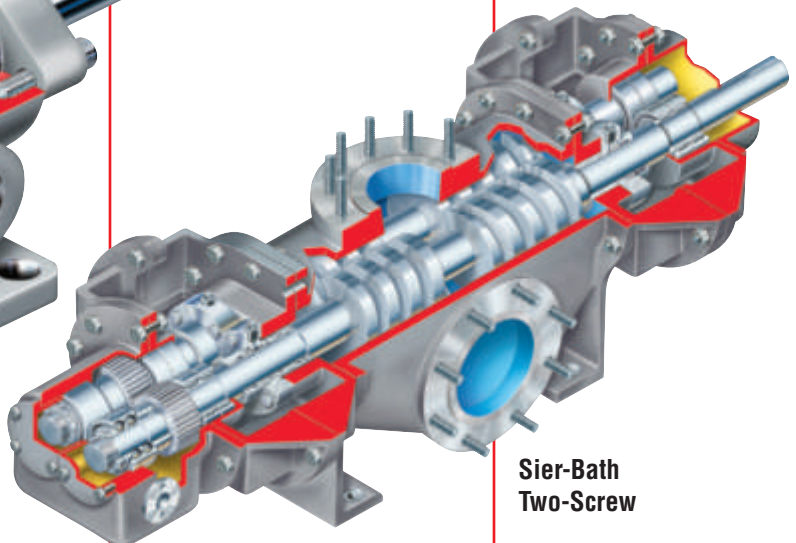

Sier-Bath  
Two-Screw

## **GR Series Between Bearing, External Gear Pump**

GR Series pumps provide high efficiency, pulse-free pumping, even under the most challenging conditions. They are designed to handle viscous fluids across a broad spectrum of flows and pressures. The GR Series' simple external design has only two moving parts and only one shaft seal to insure long life and ease of maintenance.

Available in standard sizes from 40 mm to 200 mm (1.5 in to 8 in) ports, the GR Series pumps are self-priming. Standard construction is cast iron and carbon steel.

**Between Bearing Gear Design** minimizes shaft deflection and reduces bearing loads. High pressure and high speed capabilities are improved, extending pump life and improving reliability

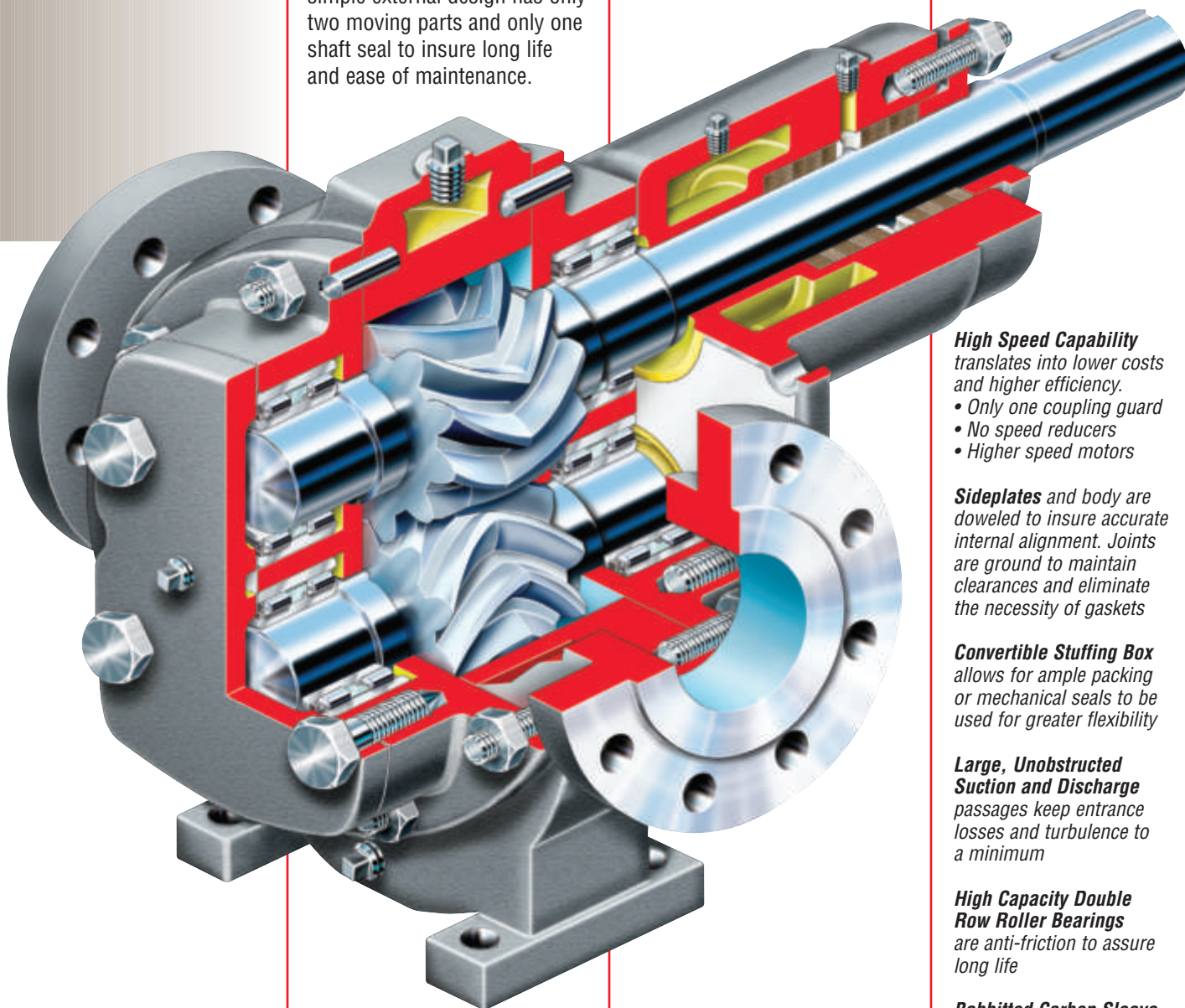

**High Speed Capability** translates into lower costs and higher efficiency.

- Only one coupling guard
- No speed reducers
- Higher speed motors

**Sideplates** and body are doweled to insure accurate internal alignment. Joints are ground to maintain clearances and eliminate the necessity of gaskets

**Convertible Stuffing Box** allows for ample packing or mechanical seals to be used for greater flexibility

**Large, Unobstructed Suction and Discharge** passages keep entrance losses and turbulence to a minimum

**High Capacity Double Row Roller Bearings** are anti-friction to assure long life

**Babbitted Carbon Sleeve Bushings** may be used when handling liquids with poor lubricity or low viscosities. Also available in antimony impregnated carbon for high temperature applications

**Shafts** are fine-grain, hot rolled medium carbon steel and are generously sized to minimize deflection

### **Operating Parameters**

- Flows to 275 m<sup>3</sup>/h (1200 gpm)
- Pressures to 35 bar (500 psi)
- Temperatures to 350°C (650°F)
- Viscosities to 33 000 cps (1 million ssu)
- Speeds to 1800 rpm

**Back Pullout Design** facilitates maintenance by allowing faster access to pump internals and enables inspection without disturbing piping

**Extra Deep Jacketed Stuffing Box** is available for hard-to-handle solutions and to cool or heat packing



### Herringbone Gear Benefits

- Quiet, pulse-free flow
- Better load carrying ability, greater strength and minimal hydraulic shock
- Gradual, continuous gear tooth engagement insuring smooth flow and no air entrapment
- Elimination of end thrust and no need for thrust bearings with inherently hydraulically balanced design
- High speed pump capability
- Off-the-shelf motors
- Durable cast iron construction for maximum wear resistance

### Standard Configurations

The GR pump is available in three basic gear widths and with multiple options. With its modular design, the GR can be customized to satisfy a wide range of applications.

**GR** – Standard gear width

**GRW** – Wider gears for higher capacities

**GRH** – Narrower gears for higher pressures



### Design Benefits

#### Flexibility

- Variety of mounting arrangements
- Horizontal and vertical suction and discharge openings
- Stuffing box accommodates packing or mechanical seals
- Product lubricated bearings

#### Reliability

- Minimal shaft deflection
- Reduced bearing loads
- Accurate alignment with two-piece doweled construction
- Reduced wear rates

#### Efficiency

- Highly efficient operation over broad range of speeds, pressures and viscosities

#### Cost Savings

- Extended life due to reduced bearing load and minimal shaft deflection
- No speed reducers
- Only one coupling guard

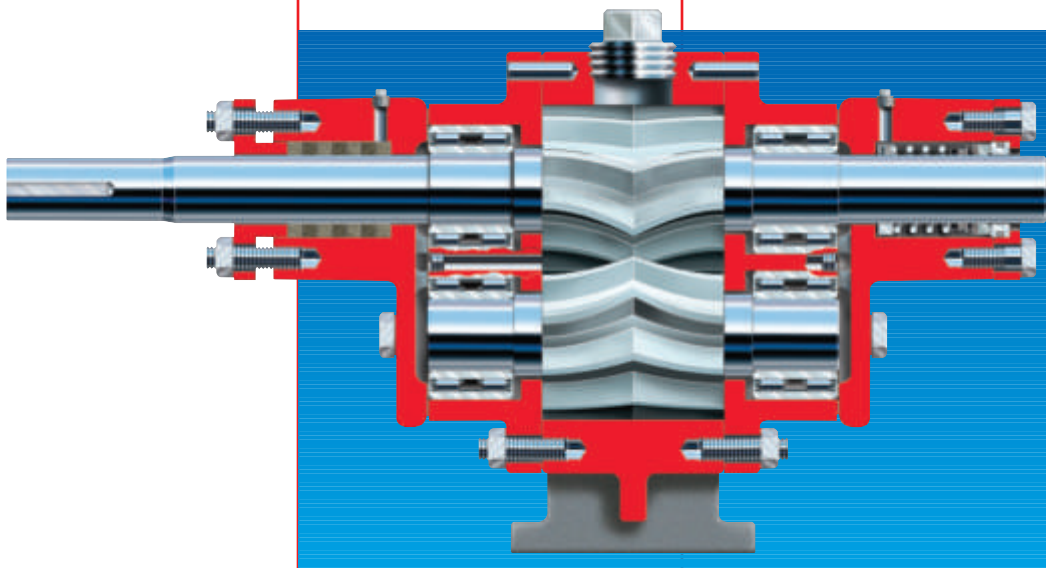

### Dual Stuffing Box

extends pump life in high suction pressure applications.

**Optional Mechanical Seal** may be used in lieu of packing. Special duty seals also are available.

### Options and Technical Data

**Direct V-Belt Drive** option includes inboard bearing with mechanical seal to carry the load of mechanical power transmission equipment without shaft deflection.

**Optional Jacketed Pump Body** allows heating or cooling of liquids before start-up and prevents overloading of driver when pumping viscous fluids.

**Available Integral Safety Relief Valve** provides short-term emergency bypass.

**Additional Options**

- Mechanical seal
- Jacketed stuffing box
- Dual stuffing box with external bearing option for high suction pressures

Standard Materials of Construction		
Component	Cast Iron	Cast Steel
Body, Stuffing Box, Bearing Cover, Gland, Sideplates	ASTM A48, Class 40 Cast Iron	ASTM A108, Class 1040 Cast Steel
Gears	Cast Iron	Cast Iron
Shaft	ASTM A108, Class 1040 Carbon Steel	ASTM A108, Class 1040 Carbon Steel
Packing	Acrylic Yarn	Graphited

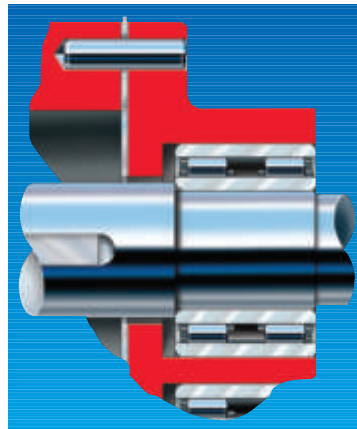

**INSUROCK® Low-Friction Wearplates** may be used to reduce sideplate and gear wear in low viscosity applications, significantly reducing total life-cycle cost. Field retrofit kits are also available.

### GR Hydraulic Coverage

**Quick Selection Chart**

Refer to the chart at the right for quick selection of the GR pump model corresponding to the desired flow rate. The ranges shown are based on typical viscosities and speeds and assume zero differential pressure. The chart's purpose is to direct the user to the appropriate performance curve, not to be a substitute for it.

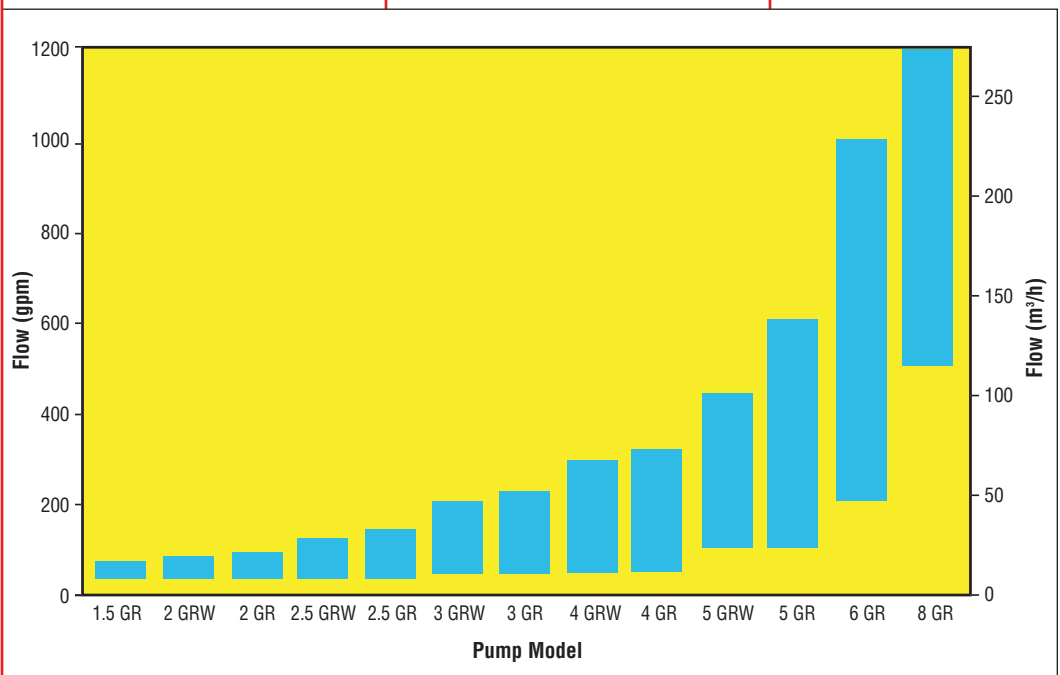

© INSUROCK is a registered trademark of Richardson Company, Inc.

**Global Engineered Services and Support**

- Total Cost Reduction*
- Asset Management*
- Product Life Cycle*
- Performance Re-rates*
- Site Diagnostics*
- Repair Services*
- Energy Management*
- Spare Parts*
- Maintenance Contracts*
- Materials Upgrades*
- Turnkey Services*
- Field Repairs*
- Installation*
- Project Supervision*
- Commissioning*
- Equipment Upgrades*
- Condition Monitoring*
- Systems Analysis*
- Field Machining*

**Service Dedication**

Flowserve Engineered Services is focused on providing customers with uncompromising service and support, where and when needed. Dedicated to delivering the highest quality support, Engineered Services integrates its extensive pump and materials engineering knowledge with creative service solutions. Engineered Services fully understands the business challenges facing customers and is prepared to manage solutions to succeed as a team.

A worldwide network of service and repair centers staffed by highly skilled engineers and technicians is available around the clock, seven days a week to respond to customer queries, to evaluate and troubleshoot problems and to provide reliable solutions.



**Strength of Experience, Commitment to Excellence**

Flowserve has long served industries requiring superior equipment performance and service life.

- Oil and gas production
- Hydrocarbon processing
- Chemical processing
- Water resources
- Power generation
- Nuclear
- Mining and mineral processing
- Pulp and paper
- General industry

Engineered Services is dedicated to maximizing equipment performance and providing reliability-centered maintenance programs for pumps and related equipment, regardless of manufacturer. Using the FlowStar™ asset management software, Engineered Services tracks performance and supports improvement programs using a service life cycle cost business approach. The results are improved reliability and increased profitability.

**Business Partner**

Flowserve partners with customers to respond to the dynamic business conditions that affect them. Flowserve will work with customers to drive efficiency, maximize throughput and control process quality. Whether user needs involve on-site technical assistance or broader project planning with full turnkey responsibility, Flowserve Engineered Services will deliver professional, reliable results.

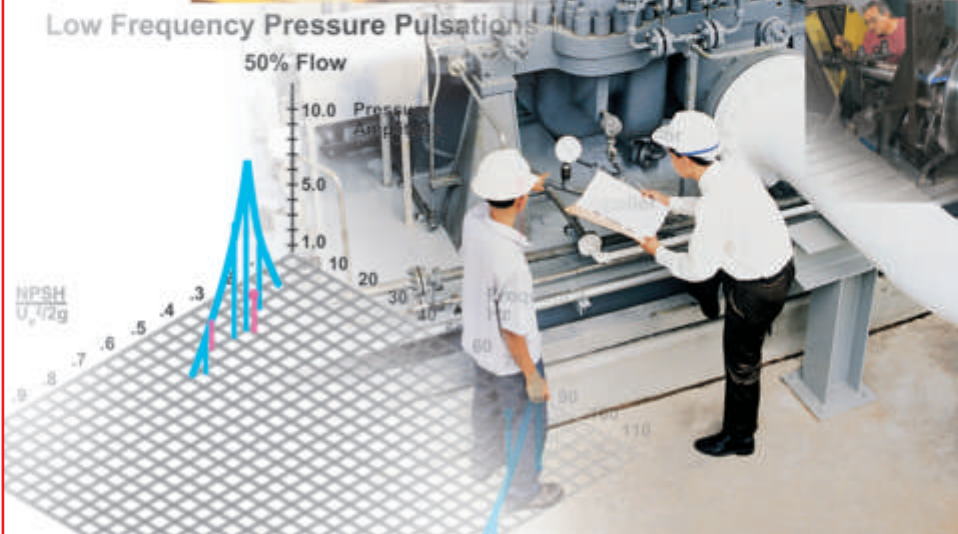

**Flowserve... Supporting Our Customers  
With The World's Leading  
Pump Brands**



**USA and Canada**

Flowserve Corporation  
Pump Division  
5215 North O'Connor Blvd.  
Suite 2300  
Irving, Texas 75039-5421 USA  
Telephone: 1 972 443 6500  
Telefax: 1 972 443 6800

**Europe, Middle East, Africa**

Flowserve Corporation  
Pump Division  
Via Rossini 90/92  
20033 Desio (Milan), Italy  
Telephone: 39 0362 6121  
Telefax: 39 0362 303396



*Your local Flowserve representative:*



Av. Colonial 5771 - Callao  
Central 464-0404 Email: [info@unitec.pe](mailto:info@unitec.pe)  
[www.unitec.pe](http://www.unitec.pe)

**Latin America and Caribbean**

Flowserve Corporation  
Pump Division  
6840 Wynnwood Lane  
Houston, Texas 77008 USA  
Telephone: 1 713 803 4434  
Telefax: 1 713 803 4497

**Asia Pacific**

Flowserve Pte. Ltd.  
Pump Division  
200 Pandan Loop #06-03/04  
Pantech 21  
Singapore 128388  
Telephone: 65 6775 3003  
Telefax: 65 6779 4607